

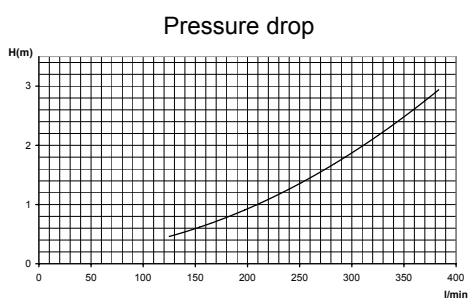

ELECTRIC HEATERS IN THERMOPLASTIC 3-18kW



- **Capacity 3-18 kW** - Fast and flexible heating of swimming pools.
- **Electric heater made of fibreglass reinforced thermoplastic** - Tough and corrosion-resistant.
- **Horizontal installation** - Eliminates air pockets and damage to the electric heating element.
- **Heating elements of Incoloy 825 are standard. The heater can be equipped with titanium heating elements** - For increased corrosion protection.
- **Equipped with overheating cutout and flow switch** - Dual safety against overheating and a too low water flow.
- **Supplied with stable brackets** - For simple and flexible installation.
- **Union couplings for Ø 50 mm pipes** - For simple installation.
- **Tested and certified by a Notified Body** - Important for product safety.



Technical data		Ampere 3-phase	
Item no.	kW	230V	400V
141600-02	3,0	8	5
141601-02	6,0	15	9
141602-02	9,0	23	14
141603-02	12,0	31	18
141604-02	15,0	38	22
141605-02	18,0	46	27

For heaters with titanium element add T after the item no. **Example: Item no. 141600T-01.**

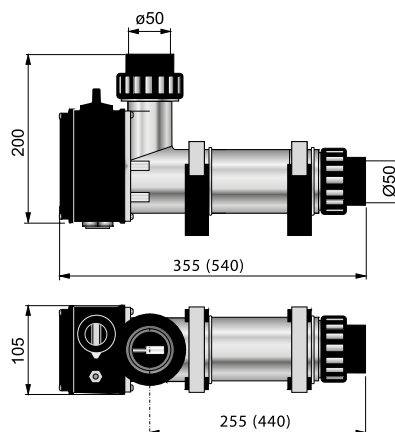

Dimensions for 12 to 18kW within brackets.
Minimum flow 90 l/min