

General description

- Designed for pH regulation of pool water by the addition of carbon dioxide CO₂.
- The regulation shall be controlled as on/off over the pH-regulator Autodos.
- This product is for use indoors in a surrounding temperature of +5°C to +40°C.
- If the equipment is not used according to specification, the protection provided by the equipment may be impaired.
- The control unit consists of a flow meter with an integral needle valve for flow control, a 230V magnetic valve and all necessary electrical components for control and indication.
- The injector is a dosing valve including a check valve and has a sintered body for maximum gas dispersion, connection is by R¹/₂", outside thread. Connect to 6/8 mm hose.
- A regulator reducing to 6 bar must be assembled to the gas bottle.
- The steel gas bottles are available in a range of sizes from 10 to 30 kg (5 or 15 m³ gas). They contain liquid CO₂ which becomes gas during release. For certain installations a heater must be mounted before the regulator. (This depends upon placement and gas consumption etc.).
- Liquid CO₂ must not be injected directly into the equipment as this can damage the installation. CO₂ can also be supplied in packages of 240kg (120m³ gas). It is also possible to connect 2, 4 or 6 gas bottles into a package on site.
- The control unit has an alarm lamp which signals when pressure is low in the gas bottle. An external output (230V) makes it possible to connect an additional warning for low gas pressure, i.e. a light.
- The unit is designed for a maximum flow of 6,5 l/min CO₂ at 6 bar.

Installation

The equipment shall be installed by an authorized electrician and it shall be preceded by an easy to reach all-pole switch, marked and certified according to the standard IEC 60947-1, IEC 60947-3 or similar.

Open the control box by loosen the four screws that hold the lid, push as shown in picture below.

It is important that the special metal-rubber gaskets are used on the high pressure side. (Included with the delivery).

The pressure line should use a semi-flexible pneumatic hose, dia. 8/6mm PN10, (10m included with the delivery).

Control unit The control unit should be mounted on a wall, placed so that its connections are vertical. CO₂ connections should be made as described above. The inflow to the unit is to the right and the outflow is to the left, (viewed from the front). The indicator lamp (green) is lit when power is applied and the magnetic valve is open. The gas flow is adjusted by the needle valve while the magnetic valve is open. The warning light (red) indicates a gas pressure too low.

Injector Place the injector into the main water flow, between the circulation pump and the filter and always after any water monitoring connections.

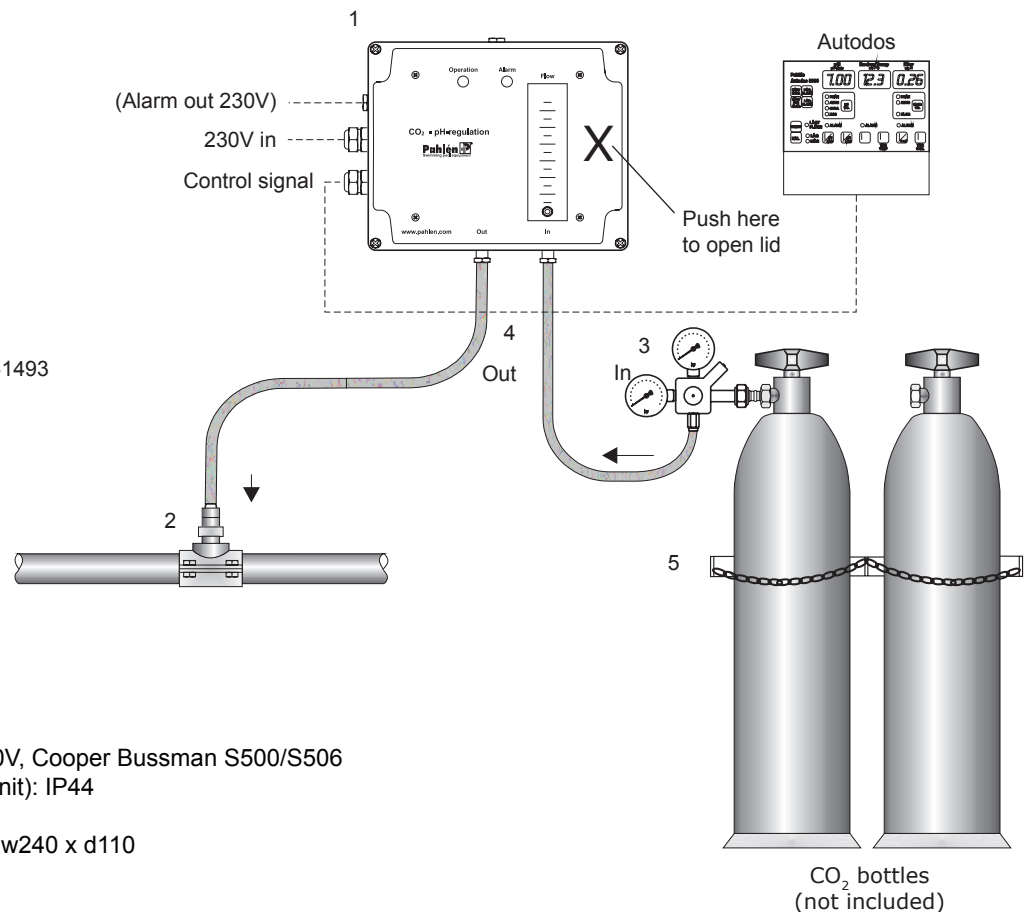

Technical specification

- Installation category 2
- Voltage: 230V
- Frequency: 50Hz
- Power: 8VA
- Built-in fuse: T500mA, 250V, Cooper Bussman S500/S506
- Protection class (control unit): IP44
- Pollution degree: 2
- Size (control unit): h190 x w240 x d110
- Weight: 1,53 kg

Circuit diagram

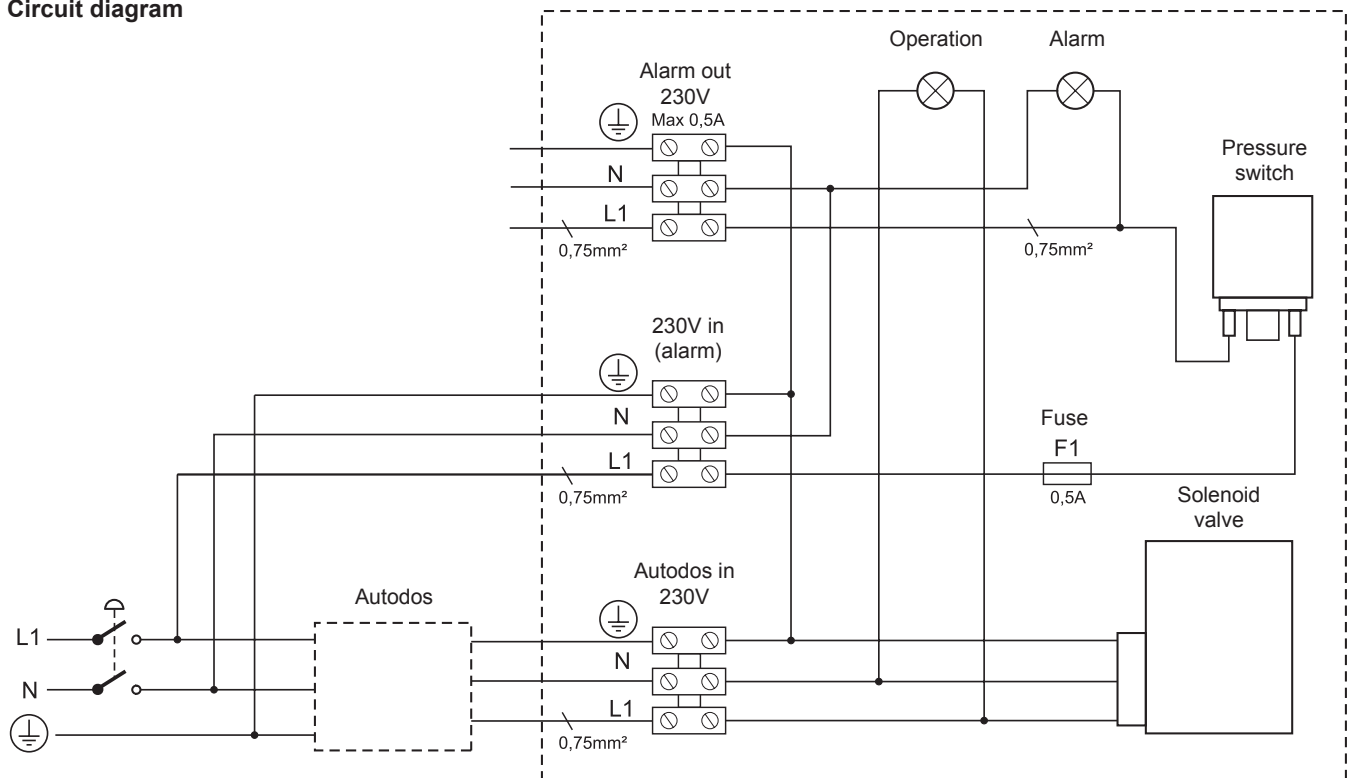

Operation

Start up

- Connect a fully charged gas bottle and open the bottle valve fully.
- Open the magnetic valve by setting the pH monitor to manual dosing.
- Regulate the CO₂ flow to about half the full capacity by means of the needle valve on the flow meter.
- Reset the pH meter to automatic dosing.
- Use the needle valve to regulate the flow according to requirements, when the magnetic valve is in the open position.

If there is no gas flow, check that:

- the bottle contains gas and that the valve is open.
- the control unit is supplied with 230V from the pH monitor.
- the dosing pipes are not blocked.
- the injector is functioning correctly.

Changing gas bottle

- Close the gas bottle valve.
- **Always inspect** the seals when changing bottles.
- Damaged or worn seals must always be replaced.

Safety

Carbon dioxide

- All involved staff should have a knowledge and understanding of CO₂.

Staff safety

- Control that all areas where CO₂ may be dispersed or accumulated are adequately ventilated.

Safety during maintenance

- Before any work is carried out, ensure that the system is completely closed down.

Maintenance

Control unit

- This does not require any routine maintenance but the gas inlets and outlets should periodically be checked for leakage. The flow meter does not require any routine maintenance.

Injector

- Periodically check the connections for leakage.